

LEXAN™ THERMOCLEAR™ SHEET

9X STRUCTURE 16-25MM

PRODUCT DATASHEET

DESCRIPTION

LEXAN™ THERMOCLEAR™ Plus 9 wall sheet is a unique sheet which combines a high outstanding thermal insulation, high optical properties and an outstanding balance of low weight and high stiffness. LEXAN THERMOCLEAR Plus 9 wall sheet is member of the LEXAN THERMOCLEAR Plus 2UV sheet range of high quality, multiwall polycarbonate glazing sheets extruded from LEXAN™ resin. LEXAN THERMOCLEAR 9 wall sheet has a two sides proprietary UV protected surface, giving superior resistance to outdoor weathering. LEXAN THERMOCLEAR Plus 9 wall is available in the standard colors Clear (112), Opal White (WH7A092X) & Solar control IR green (GN8B038T).

PRODUCT AVAILABILITY

SABIC GRADE NAME	STANDARD WIDTHS (MM)	AVAILABLE LENGTHS (MM)	(SHEETS/PALLET) **
LT2UV169X	980-1250-2095	3000-13000	25
LT2UV209X	980-1250-2095	3000-13000	20
LT2UV259X	980-1250-2095	3000-13000	20

** Please check our latest product guide for MOQ & Stock (MTI) items

TYPICAL PROPERTY VALUES

GRADE	(MM)	STRUCTURE	WEIGHT (KG/M ²)	^ U VALUE (W/M ² K)	RIB DISTANCE (MM)
LT2UV169X	16	9 wall X structure 16-25MM	2.50	1.77	20.00
LT2UV209X	20	9 wall X structure 16-25MM	2.80	1.59	20.00
LT2UV259X	25	9 wall X structure 16-25MM	3.00	1.40	20.00

^ U-values based on SABIC calculated values according ISO 10077

LIGHT TRANSMISSION STANDARD COLORS

GRADE	# LT CLEAR (%)	LT OPAL WHITE (%)	LT IR GREEN (%)
LT2UV169X	54	47	38
LT2UV209X	53	47	37
LT2UV259X	51	44	36

Light transmission measurements acc. ISO 9050

STRUCTURES & NOMENCLATURES

169X25 structure

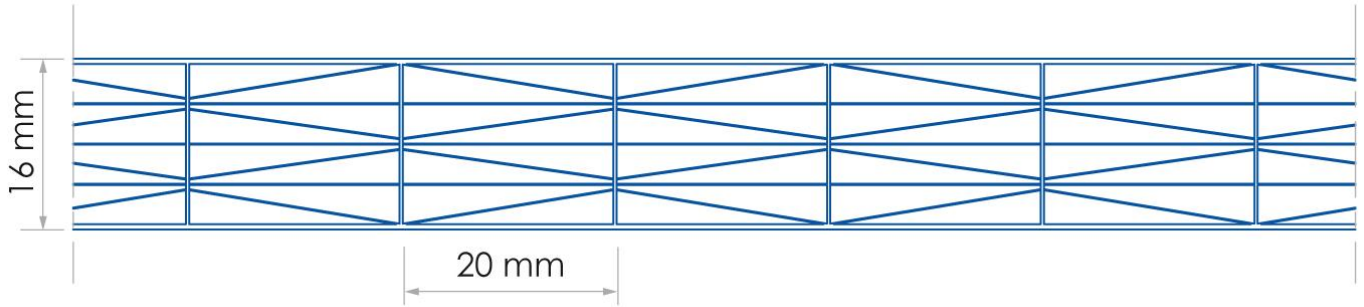

209X28 structure

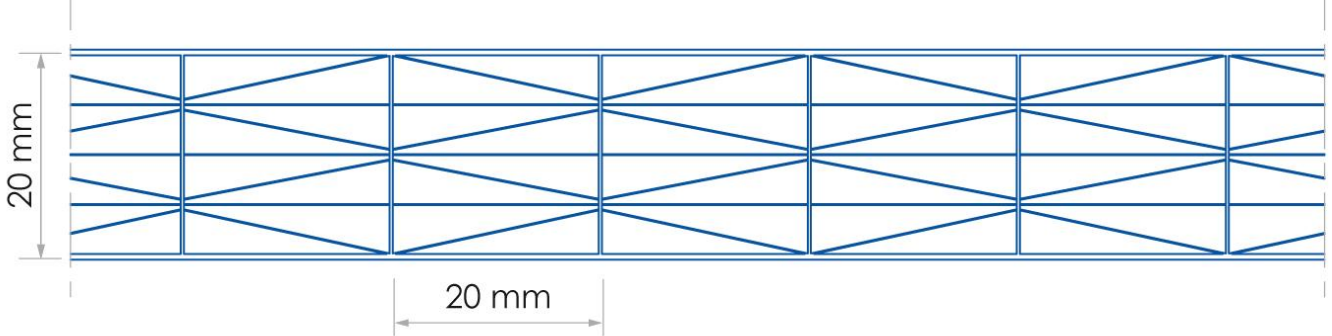

259X30 structure

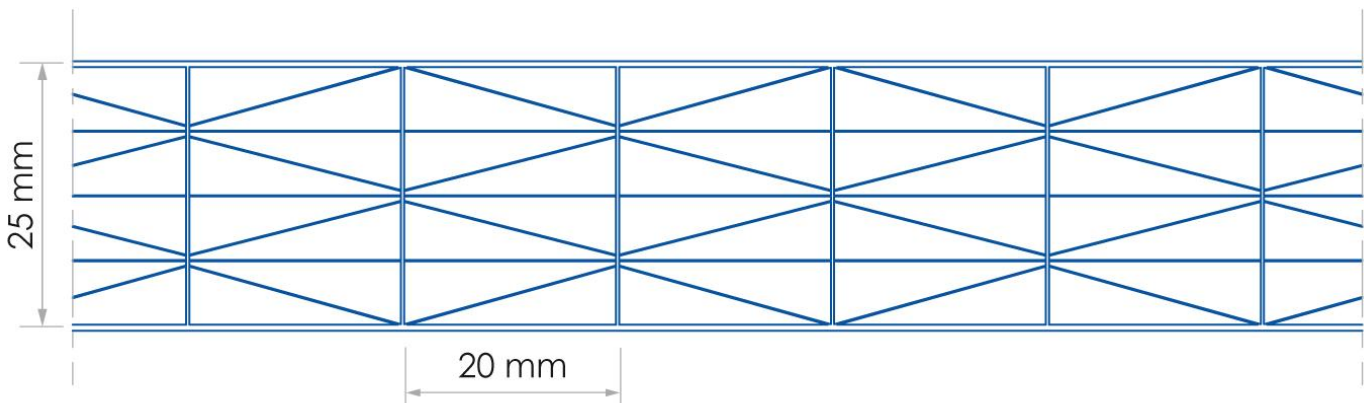

COLD CURVED GLAZING

LEXAN THERMOCLEAR sheet can be successfully cold curved over curved support glazing profiles, to suit many glazing applications, e.g. domes, roof-lights, etc. Providing the radius is not below the minimum recommended value of 2400mm, then the introduced stress by cold-curving will not have any adverse effect upon the mechanical performance of the sheet. Sheets must always be bent longitudinally, never across the width of the sheet. Sheet length needs to be greater than the sheet width to facilitate curvature; in practice, a ratio of 1:2 or less is never contemplated because of the practicalities of installation geometry.

GRADE	MIN. BENDING RADIUS (MM) 150X GAUGE
LT2UV169X	2400
LT2UV209X	3000
LT2UV259X	N/A

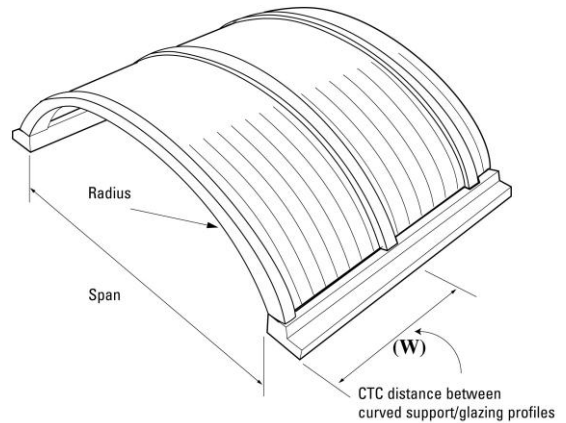

COATING AVAILABILITY

LEXAN THERMOCLEAR 2UV PLUS SHEET:

LEXAN THERMOCLEAR 2UV plus sheet is the standard coating applied to both sides of the SABIC multiwall sheet and gives the product an excellent UV weathering performance.

LEXAN THERMOCLEAR SUNXP SHEET:

LEXAN THERMOCLEAR SunXP sheet is a coating which even enhances the weathering performance to the extent that SABIC offers a fifteen year written limited warranty with this product.

LEXAN THERMOCLEAR SOLAR CONTROL IR (SCIR) SHEET:

LEXAN THERMOCLEAR Solar Control IR sheet reduces significantly the solar transmission coming from the sun while simultaneously offering high levels of light transmission.

LEXAN THERMOCLEAR SOLAR CONTROL SHEET:

LEXAN THERMOCLEAR Solar Control sheet, the interior surface side will have a full Solar Control print lowering the solar transmittance coming from the sun light.

LEXAN THERMOCLEAR VENETIAN SHEET:

LEXAN THERMOCLEAR Venetian sheet, the interior surface side will have Venetian printed stripes as an aesthetic view of the product.

SOLAR TRANSMISSION

LEXAN THERMOCLEAR sheet is essential opaque to all wavelengths below 385 nanometers. This useful shielding property can prevent discoloration of sensitive materials placed under or behind. Solar heat gain within a building is caused by heat input from radiation emitted from the sun. Sunlight entering the building heats the air both directly and through absorption by the framework, furniture, etc. and is released as infrared energy. In combination with the insulation properties of LEXAN THERMOCLEAR sheet, this prevents heat escaping faster than it is created causing a temperature increase, the so-called 'greenhouse effect'. The temperature can be controlled by venting, often in combination with special tinted opal white or LEXAN THERMOCLEAR SC IR which contains a proprietary additive which selectively absorbs the near infrared region of the light. LEXAN THERMOCLEAR is therefore available in many different colors or with IR additives, which both cuts down the brightness of sunlight to a pleasing level and reduces heat buildup inside the building. Calculations for solar heat input through glazing are normally based on data published in 'The Institution of Heating and Ventilating Engineers Guide Book'. These calculations are based on clear glass and correction factors or shading coefficients are then applied when alternative glazing materials are used.

UV RESISTANCE

The complete LEXAN THERMOCLEAR sheet range features a proprietary both sides surface treatment designed to protect the sheet against the degrading effects of ultra-violet radiation in natural sunlight. Both sides UV protected surfaces offers advantage in economically cutting the sheet in desired shapes, and installation mistakes are minimized since both sheet surfaces may be faced outwards.

WARRANTY

SABIC offers a Ten (10) Year Limited Written Warranty on LEXAN THERMOCLEAR sheet covering discoloration, loss of light transmission and loss of strength due weathering. See warranty for exact details.

FIRE TEST PERFORMANCE

LEXAN THERMOCLEAR sheet has good fire performance against many national fire codes dependent on thickness and color. Please check with the local sales office for details.

IMPACT STRENGTH

LEXAN THERMOCLEAR sheet has outstanding impact performance over a wide temperature range, -40°C to +120°C, and also after prolonged outdoor exposure. As a roof glazing material LEXAN THERMOCLEAR 2UV sheet is subjected to the extremes of weather; storms, hail stones, wind, snowfalls and ice formation. Under these conditions, the product is virtually unbreakable and is able to accommodate the subsequent temperature change to sunny conditions without breaking or buckling. Please refer to the warranty for details.

CONTACT US:

Middle East and Africa

SABIC Global Headquarters
PO Box 5101
Riyadh 11422
Saudi Arabia
T +966 (0) 1 225 8000
F +966 (0) 1 225 9000
E info@sabic.com

Email

sfs.info@sabic-ip.com

Americas

Specialty Film & Sheet
1 Plastics Avenue
Pittsfield, MA 01201
USA
Toll-free 1 800 323 3783
T 1 413 448 6655
F (888) 443 2033
E Spinside.sales@sabic-ip.com

Europe

Specialty Film & Sheet
Plasticslaan 1
4612 PX
Bergen op Zoom
The Netherlands
T +31 (0)164 293678
F +31 (0)164 293272
E sfs.info@sabic-ip.com

Asia Pacific

Specialty Film & Sheet
2550 Xiupu Road
Pudong
201319 Shanghai
China
T +86 21 2037 8188
F +86 21 2037 8288
E sfs.info@sabic-ip.com

DISCLAIMER: THE MATERIALS, PRODUCTS AND SERVICES OF SAUDI BASIC INDUSTRIES CORPORATION (SABIC) OR ITS SUBSIDIARIES OR AFFILIATES ("SELLER") ARE SOLD SUBJECT TO SELLER'S STANDARD CONDITIONS OF SALE, WHICH ARE AVAILABLE UPON REQUEST. INFORMATION AND RECOMMENDATIONS CONTAINED IN THIS DOCUMENT ARE GIVEN IN GOOD FAITH. HOWEVER, SELLER MAKES NO EXPRESS OR IMPLIED REPRESENTATION, WARRANTY OR GUARANTEE (i) THAT ANY RESULTS DESCRIBED IN THIS DOCUMENT WILL BE OBTAINED UNDER END-USE CONDITIONS, OR (ii) AS TO THE EFFECTIVENESS OR SAFETY OF ANY DESIGN OR APPLICATION INCORPORATING SELLER'S MATERIALS, PRODUCTS, SERVICES OR RECOMMENDATIONS. UNLESS OTHERWISE PROVIDED IN SELLER'S STANDARD CONDITIONS OF SALE, SELLER SHALL NOT BE RESPONSIBLE FOR ANY LOSS RESULTING FROM ANY USE OF ITS MATERIALS, PRODUCTS, SERVICES OR RECOMMENDATIONS DESCRIBED IN THIS DOCUMENT. Each user is responsible for making its own determination as to the suitability of Seller's materials, products, services or recommendations for the user's particular use through appropriate end-use and other testing and analysis. Nothing in any document or oral statement shall be deemed to alter or waive any provision of Seller's Standard Conditions of Sale or this Disclaimer, unless it is specifically agreed to in a writing signed by Seller. Statements by Seller concerning a possible use of any material, product, service or design do not, are not intended to, and should not be construed to grant any license under any patent or other intellectual property right of Seller or as a recommendation for the use of any material, product, service or design in a manner that infringes any patent or other intellectual property right.

SABIC and brands marked with TM are trademarks of SABIC or its subsidiaries or affiliates.
© 2014 Saudi Basic Industries Corporation (SABIC). All Rights Reserved.

[†] Any brands, products or services of other companies referenced in this document are the trademarks, service marks and/or trade names of their respective holders.

www.sabic.com/sfs

